

CAD FILE:

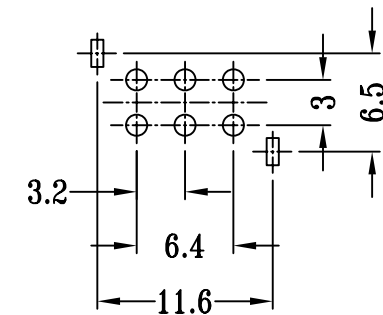
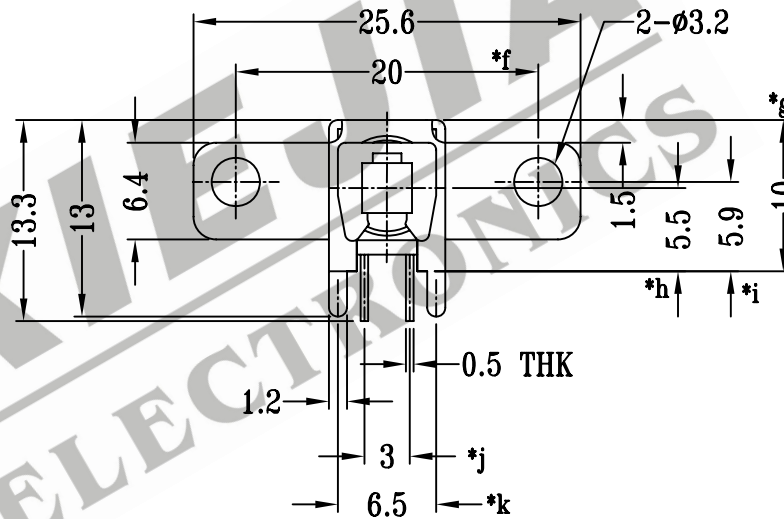
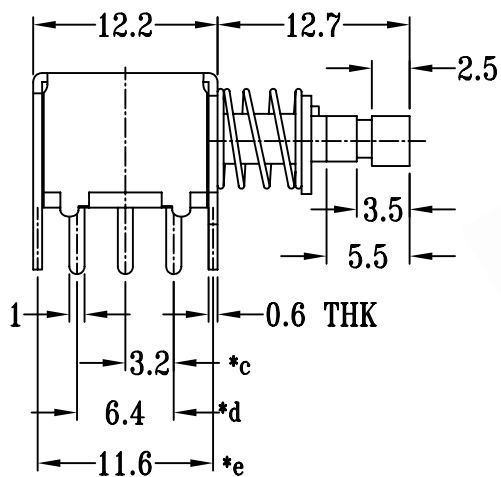
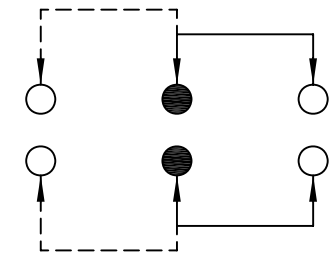
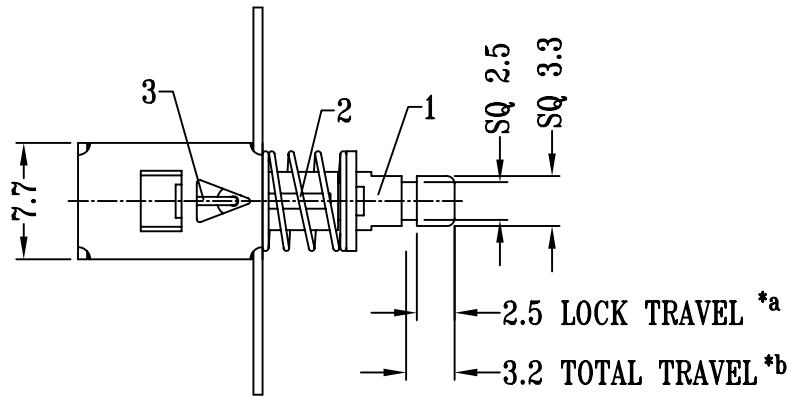

P.C.B LAYOUT

NO.	PARTS	MATERIALS	Q'TY	FINISH							
9	CONTACT CLIP	PBS STRIP	2	Ag PLATED	TOLERANCE UNLESS SPECIFIED WITHIN: 1.5±0.1mm OVER : 1.5±0.2mm	SHENZHEN XIEJIA ELECTRONICS CO.,LTD.					
8	BLOCK	STEEL STRIP	1	Ni PLATED		ISSUE	DATE	DESCRIPTIONS OF REVISION		APPD.	
7	TERMINAL	BRASS STRIP	6	Ag PLATED OVER Ni PLATED							
6	BASE	PHENOLIC RESIN	1	NATURAL		TITLE : PUSH SWITCH		UNIT : mm	DRWG NO.: XJ-DR-PS22F06-00		
5	FRAME	STEEL STRIP	1	Ni PLATED		MODEL: PS-22F06 (LOCKED)		SCALE: 2 : 1	DWN.	ZHOUYU	2002-9-21
4	SPRING PLATE	PBS STRIP	1	NATURAL		ALL MATERIALS MUST BE COMPLIANT TO ROHS			CHK'D	FANGYING	2002-9-21
3	LOCK NEEDLE	PBS WIRE	1	NATURAL				APPD.	KANGXINAN	2002-9-21	
2	SPRING	STEEL WIRE	1	Ni PLATED							
1	KNOB	POM	1	BLACK							

注:带"*"表示关键尺寸(11个)